

Assignment #1:

Become familiar with the basic drawing tools in SketchUp. Draw the following shapes and make sure they are the same sizes as shown below.

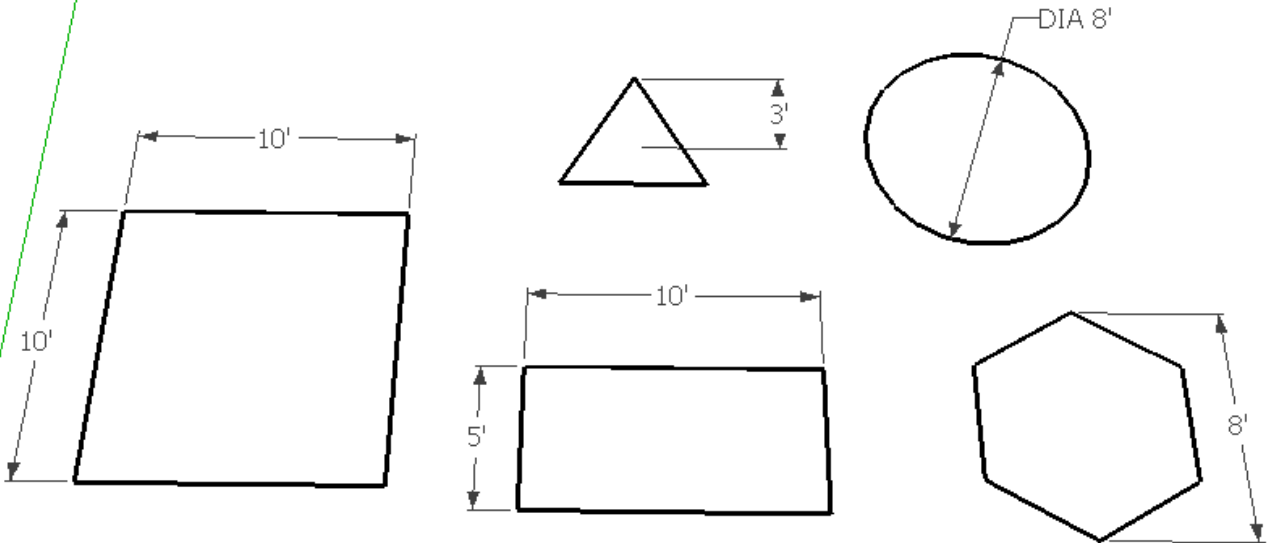

Save this file in your folder as 'assignment 1'. This assignment is worth **20 points**.

Assignment #2:

Become familiar with the Line tool. Draw the following shapes, making sure they are the same sizes as shown below.

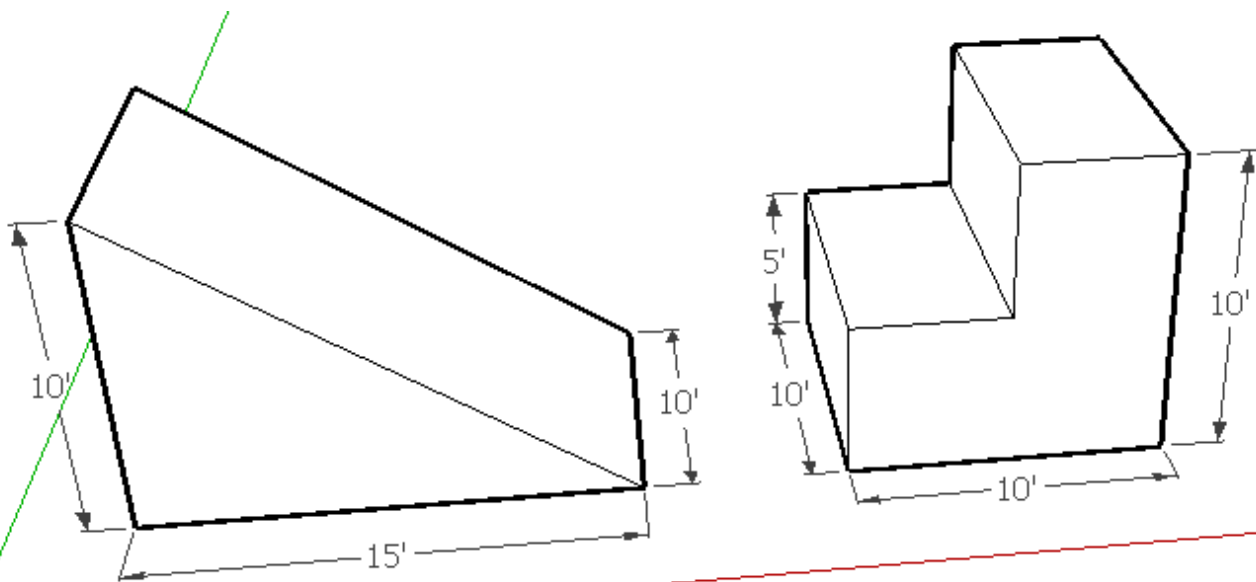

Save this file in your folder as 'assignment 2'. This assignment is worth **20 points**.

Assignment #3:

Begin with a perfect cube that is 10' on all sides. Next draw on ALL 6 sides of the cube to create your own unique 3D drawing.

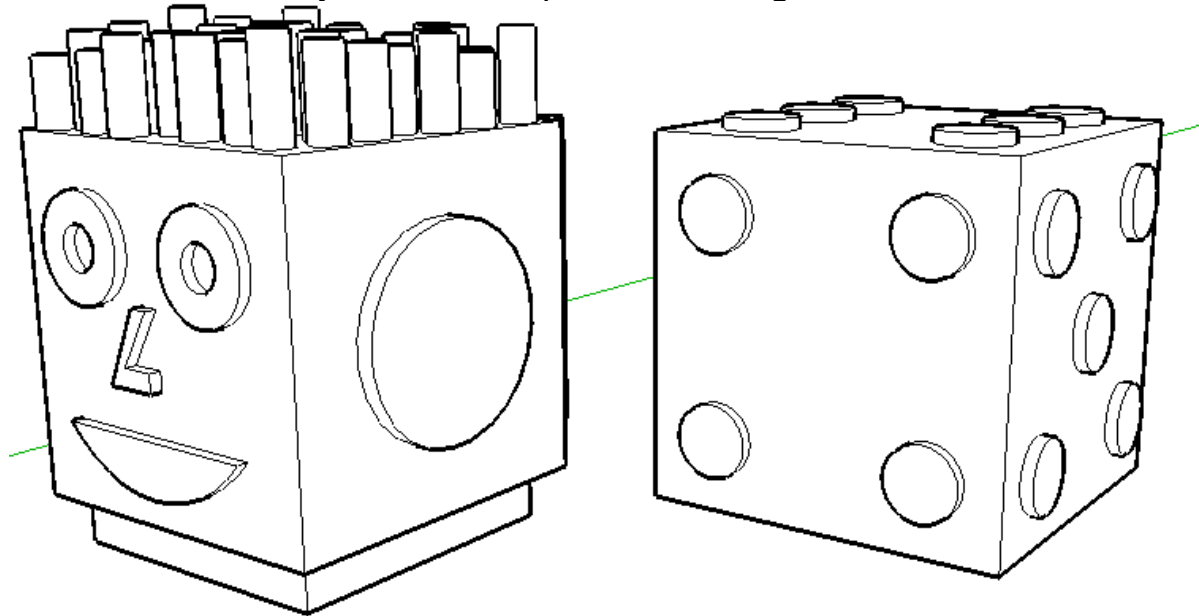

Save this file in your folder as 'assignment 3'. This assignment is worth **20 points**.

Assignment #4:

Begin with a 10' x 10' x 5' tall box. Add the roof line, a door, and a chimney.

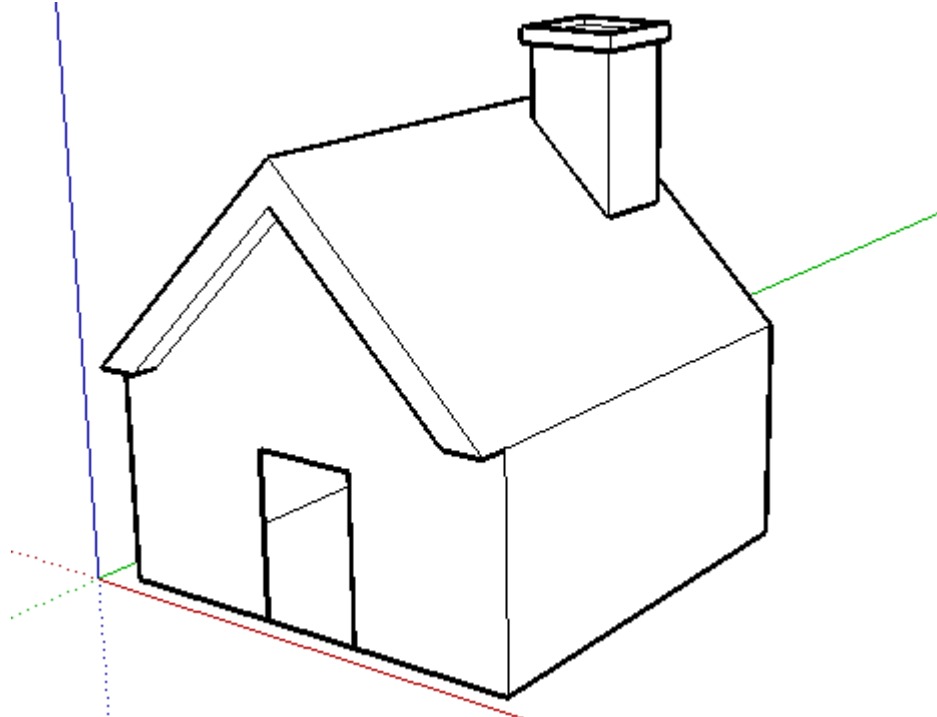

Save this file in your folder as 'assignment 4'. This assignment is worth **20 points**.

Assignment #5:

Learn how to Group objects to use in your models. Create at least 3 of your own objects, and group them together.

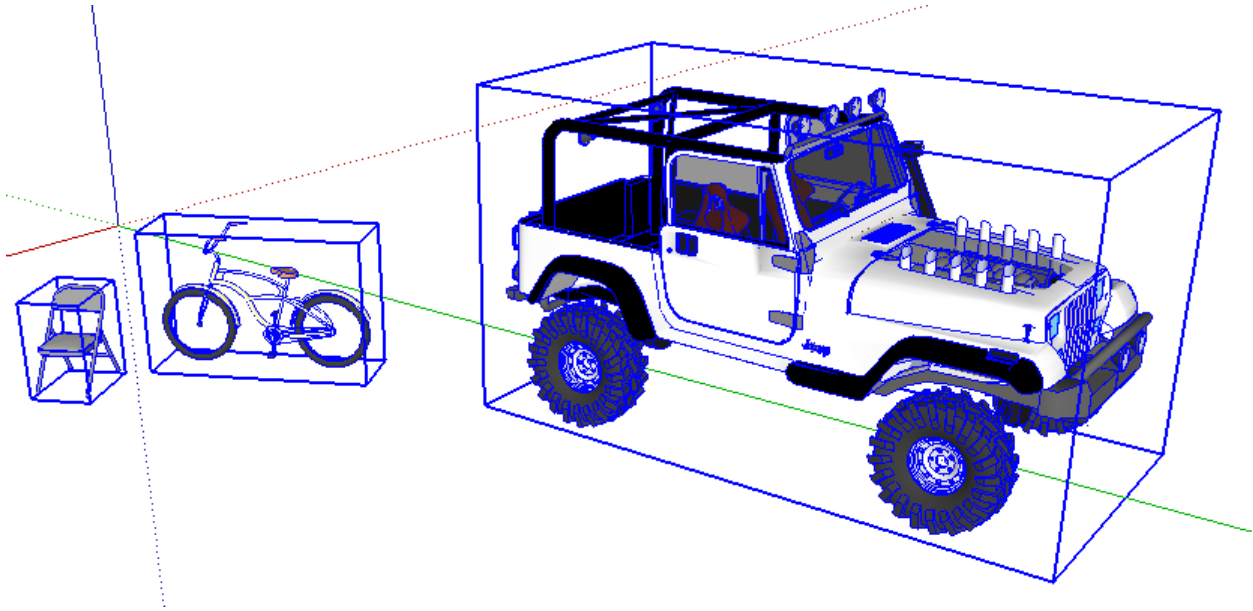

Save this file in your folder as 'assignment 5'. This assignment is worth **20 points**.

Assignment #6:

Create any shape with at least 10 faces and add color to it.

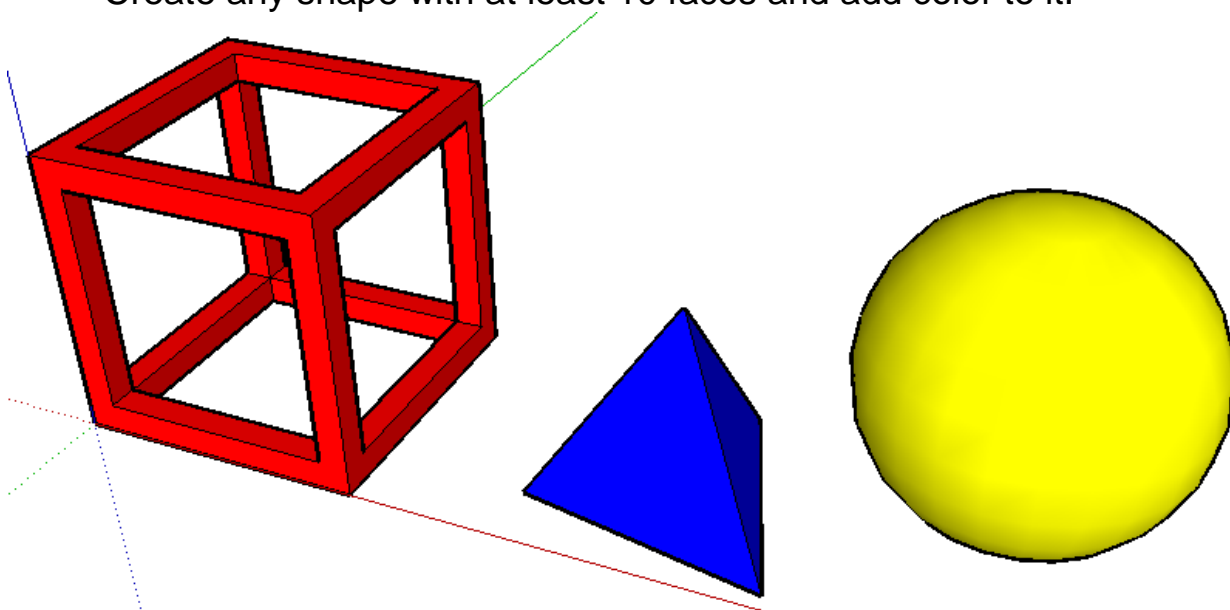

Save this file in your folder as 'assignment 6'. This assignment is worth **20 points**.

Assignment #7:

Create a rectangular and circular array of cylinders as shown below.

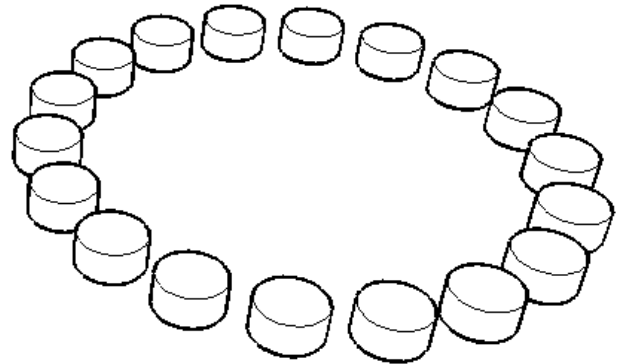
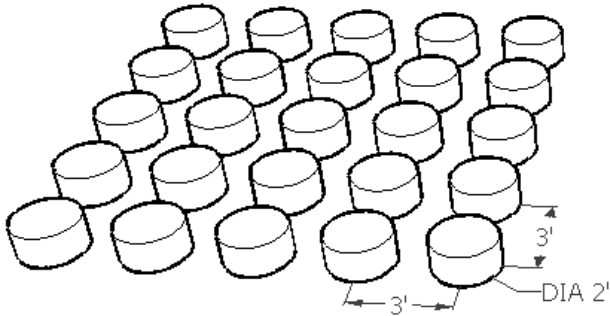

Save this file in your folder as 'assignment 7'. This assignment is worth **20 points**.

Assignment #8:

Learn to use the 3D Warehouse as a resource. Create a model with at least 5 objects that you have downloaded.

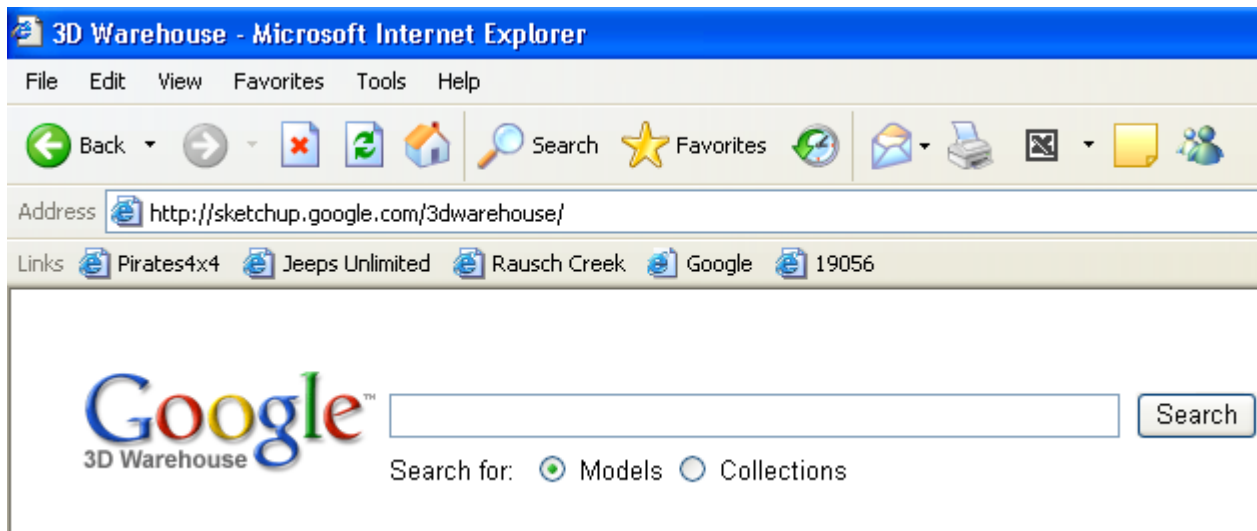

Save this file in your folder as 'assignment 8'. This assignment is worth **20 points**.

Assignment #9:

Create a kids toy. The final toy should consist of at least 6 pieces (groups of parts).

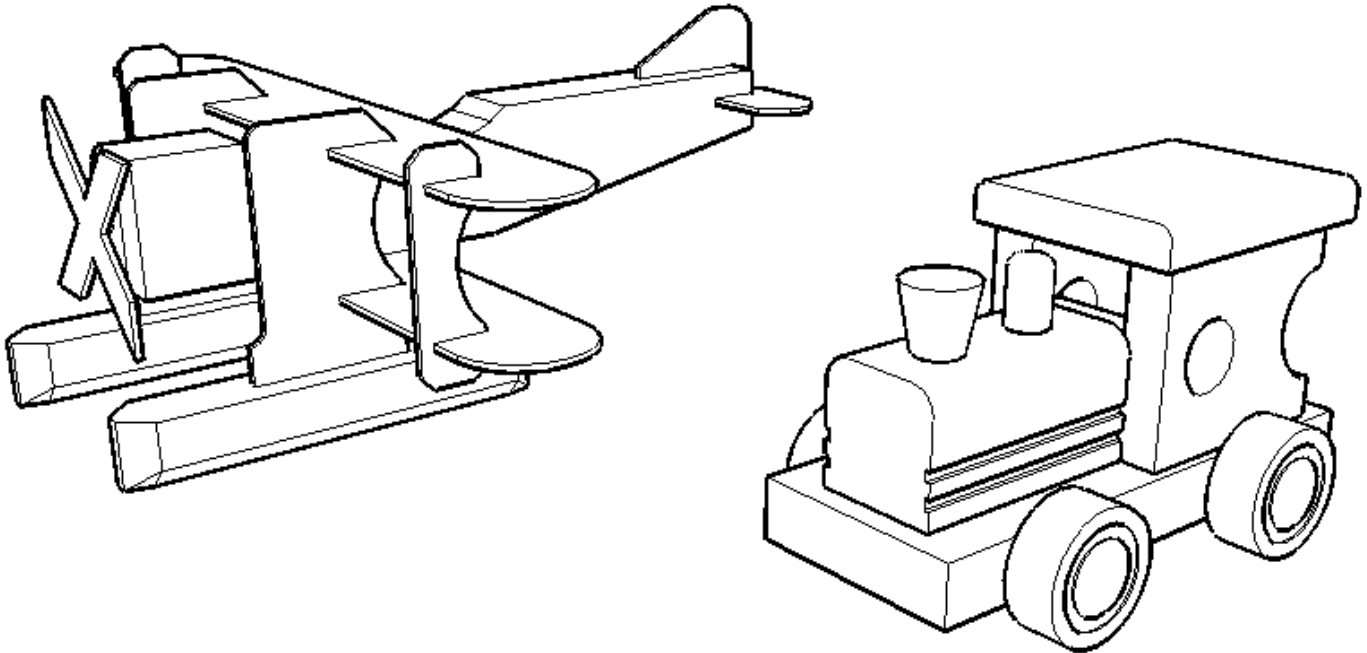

Save this file in your folder as 'assignment 9'. This assignment is worth **60 points**.

Assignment #10:

Create at least 9 objects. Put each object in a Layer and change the visibility.

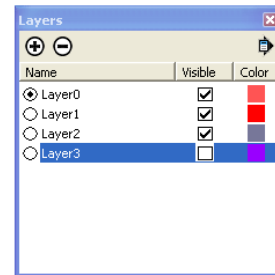
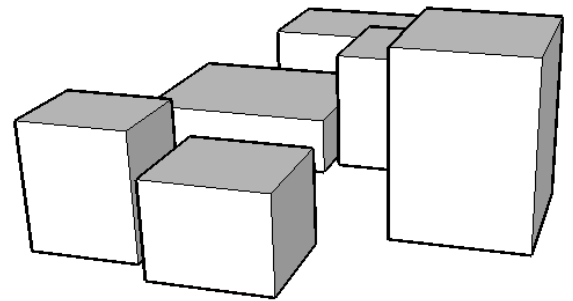
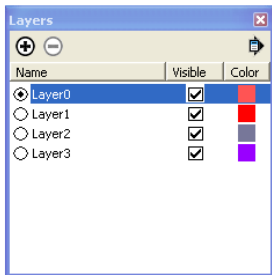
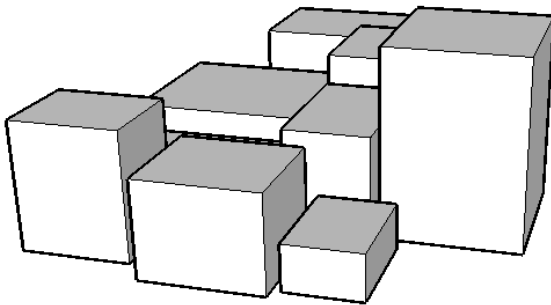

Save this file in your folder as 'assignment 10'. This assignment is worth **20 points**.